

SPECIFICATIONS

| | | |
|---------------------------------------|-------------------------------|------------------------------|
| Model | KC250HR-4 | |
| Engine | Make | Kubota |
| | Model | V2203-M |
| | Output kW (PS) / rpm | 33.4 (45.5) / 2300 |
| | Displacement cc | 2197 |
| | Cooling system | Water cooled |
| Service weight | kg | 2700 |
| Max. loading capacity | kg | 2500 |
| Skip tipping system | Hydraulic | |
| Dumping direction | Rotary / 180° | |
| Dumping height | 920 | |
| Transmission | Type | Hydrostatic transmission HST |
| | Hydraulic pump | 2 variable pumps |
| | Flow (for each pump) ℓ/min | 2 x 54 |
| | Hydraulic motors | Radial pistons motors |
| | Max. pressure bar | 350 |
| | Main valve | 2 |
| Dimensions | Overall length mm | 3595 |
| | Overall height mm | 2400 |
| | Overall width mm | 1550 |
| Internal skip dimensions | Length mm | 2105 |
| | Width mm | 1300 |
| | Height mm | 494 / 670 |
| | Dumping angle deg | 84° |
| | Heaped volume m ³ | 1.49 |
| Undercarriage | Level volume m ³ | 1.09 |
| | Ground clearance mm | 344 |
| | Tumbler distance mm | 1950 |
| | Rubber shoe width mm | 320 |
| | Track roller | 6 |
| Travelling speed | 1st speed km/h | 0 ~ 6 |
| | 2nd speed km/h | 0 ~ 11 |
| (Forward / Reverse) Max. gradeability | Front 20° / Side 25° | |
| Fuel tank capacity | ℓ | 40 |
| Hydraulic oil tank capacity | ℓ | 51 |
| Ground pressure | (Unloaded) gr/cm ² | 308 |
| | (Loaded) gr/cm ² | 593 |

*The data have been measured on the standard version. Specifications are subject to change without notice.

DIMENSIONS

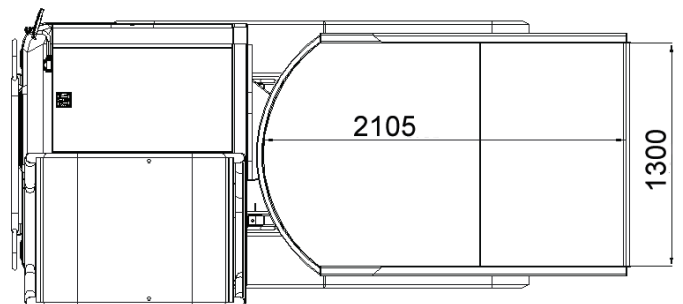
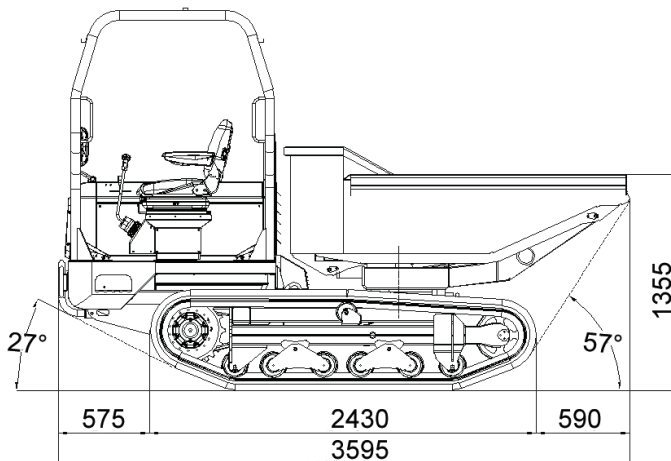
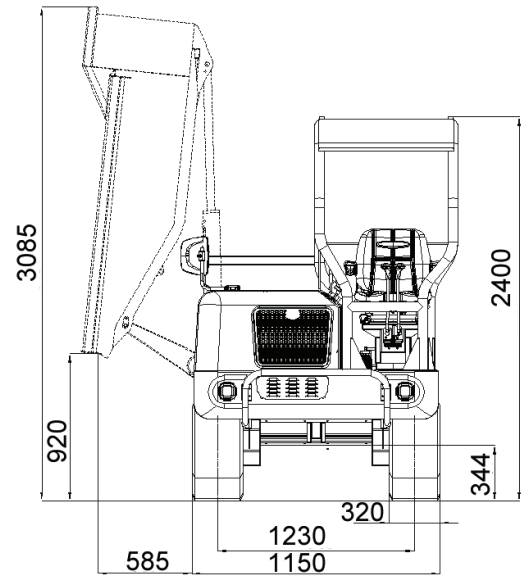

★ All image's shown are for brochure purposes only.

When operating the tracked dumper always wear proper PPE clothing and equipment in accordance to local legal and safety regulations.



hire@pjpk.com
www.pjpk.com

KUBOTA U.K. LTD
Dormer Road, Thame, Oxfordshire
OX93UN, U.K.
Phone: (44) 01 844-268140
Fax: (44) 01 844-216685
http://www.kubota-global.net